



Introducción. Mejoras Tecnológicas

Motivación:

- ✓ ¿Cómo clasificamos las técnicas de mejora en monoprocesadores?
- ✓ ¿Cuál es el motor de las mejoras tecnológicas?
- ✓ ¿Cómo evolucionan las mejoras tecnológicas?
- ✓ ¿Cómo es el proceso de fabricación de circuitos integrados?
- ✓ ¿Cuál es el futuro de la industria de los semiconductores?



Introducción. Mejoras Tecnológicas

- Técnicas para mejora de prestaciones en monoprocesadores
- Mejoras Tecnológicas
 - ✓ Aumento de la capacidad de integración
 - ✓ Fabricación de circuitos integrados
 - ✓ Futuro de la industria de los semiconductores



Técnicas

- Mejoras tecnológicas
 - Aumento de la capacidad de integración
- Uso eficiente de la tecnología disponible
 - - MEMORIA: Jerarquía de Memoria
 - PROCESADOR:
 - ✓ Segmentación
 - ✓ Paralelismo: Múltiples U. Funcionales, Superescalabilidad, Múltiples Núcleos
 - E/S: Arrays de Discos (Discos RAID)
- Mejora de la comunicación Software-Hardware
 - - Procesadores RISC/CISC
 - Procesadores SIMD: Matriciales y Vectoriales



Capacidad de Integración

- Capacidad de integración ↑
 - ⇒ N° Componentes/Chip ↑ ⇒ Coste ↓
 - ⇒ Velocidad conmutación transistores ↑ ⇒ freloj ↑ ⇒ Rend ↑
- Ejemplos: Memorias y Procesadores

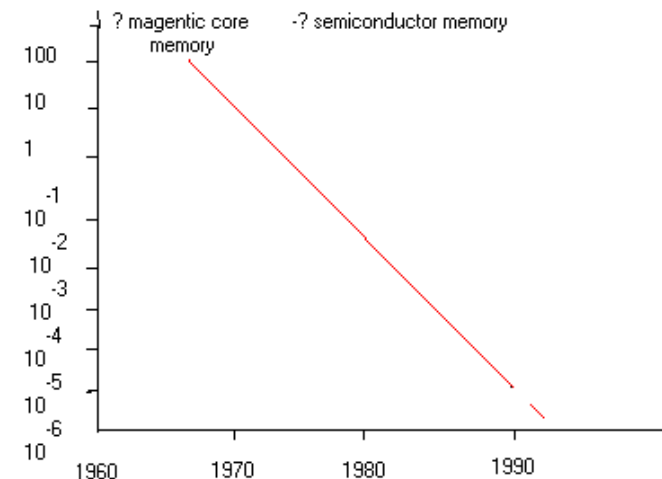
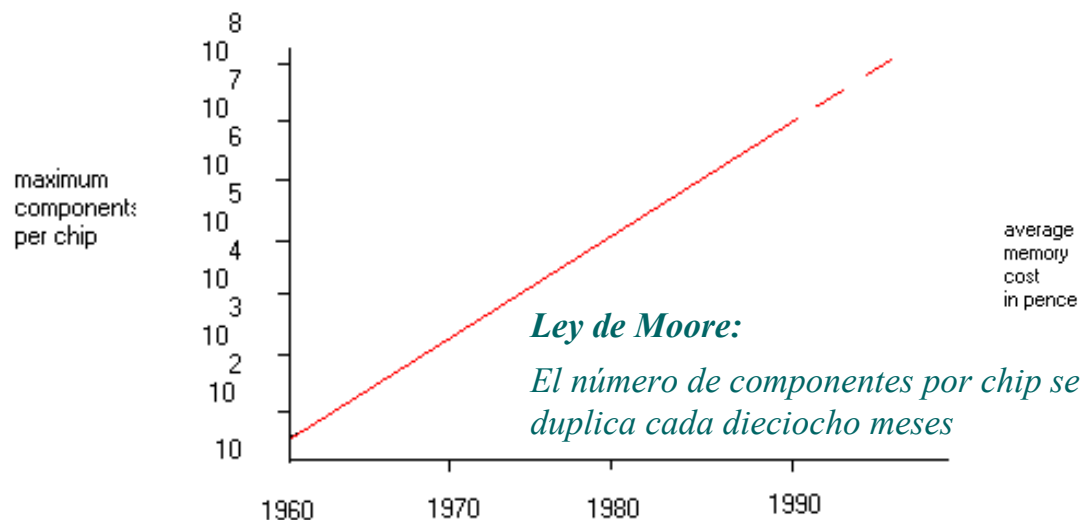



Capacidad de Integración

- Aumento del nivel de integración (✓
 - ✓ N° de componentes por chip $\sim n^2$
 - ✓ Velocidad de conmutación $\sim n$

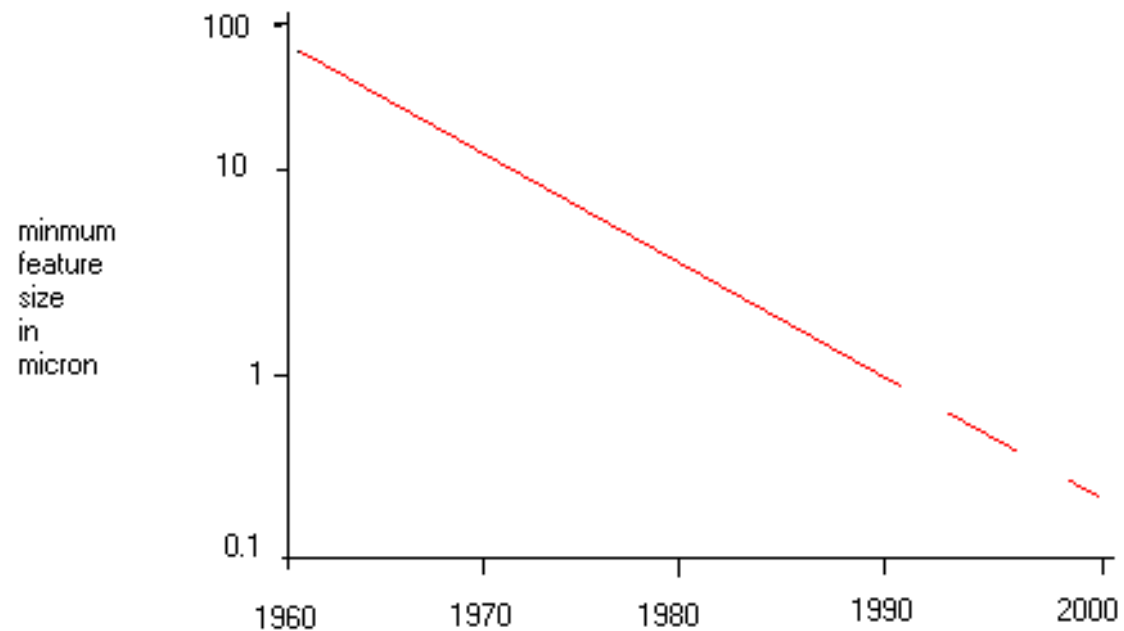



Capacidad de Integración

- Aumento de la superficie de chip (✓
 - ✓ N° de componentes por chip $\sim d^2$
 - ✓ Velocidad de conmutación ~ 1

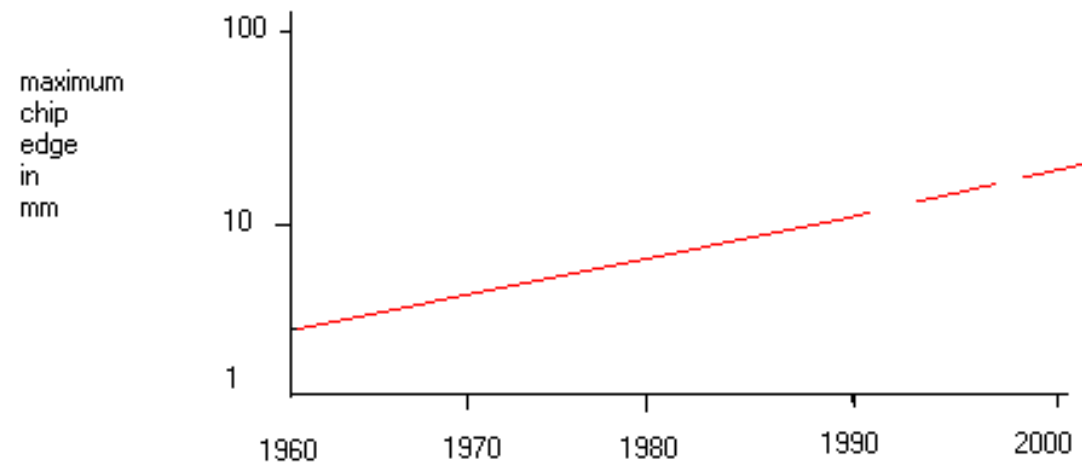



Capacidad de Integración

- Capacidad de cálculo de un chip
 - ✓ N° de componentes \times Velocidad de conmutación
 - ✓
- Desafío:
 - ✓ convertir la capacidad de cálculo en incremento real de rendimiento
 - ➔
- Ejemplos:
 - ✓ Memorias de mayor tamaño
 - ✓ Buses internos más anchos
 - ✓ Más niveles de cache en el propio procesador
 - ✓ Reducción del número de chips
 - ✓



Ley de Moore

Worldwide Transistor Production

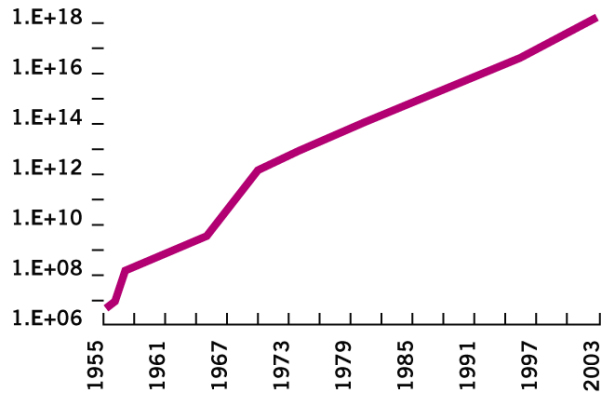

Average Price Per Transistor (nanodollars)

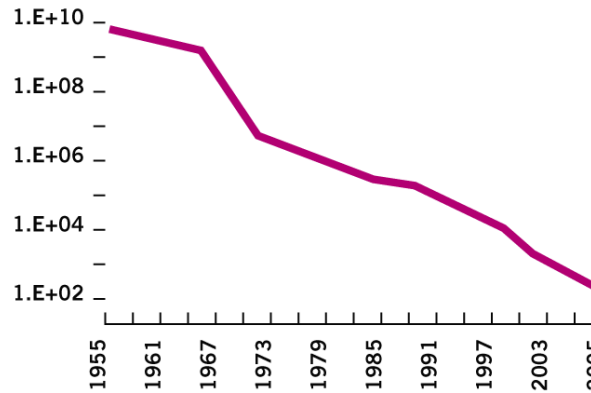

Semiconductor Feature Size (nanometers)

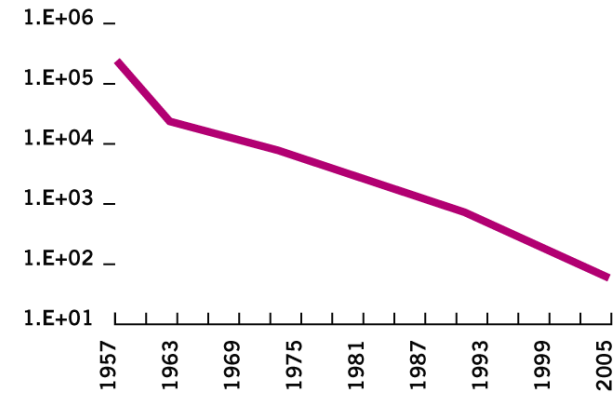

MOORE'S LAW: BY THE NUMBERS

Above are three metrics that graphically demonstrate the effects of Moore's Law. Constantly improving semiconductor technology has driven exponential increases in the number of transistors that can be placed on a chip while simultaneously driving reductions in cost and increases in performance. The result: chips that get faster, better, and cheaper every year.

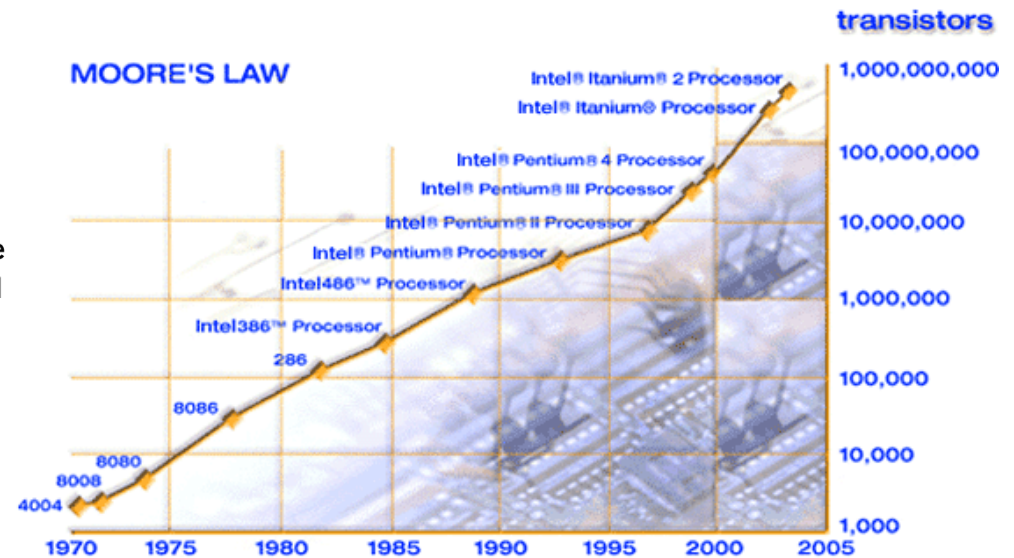



Fabricación de Circuitos Integrados

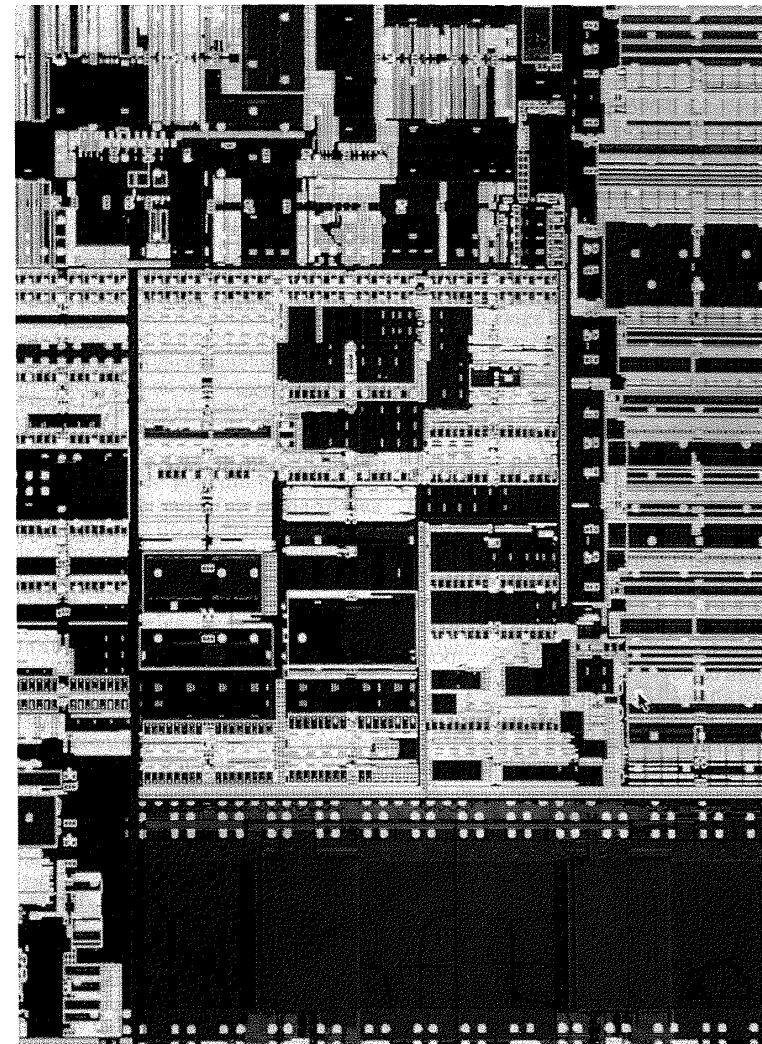
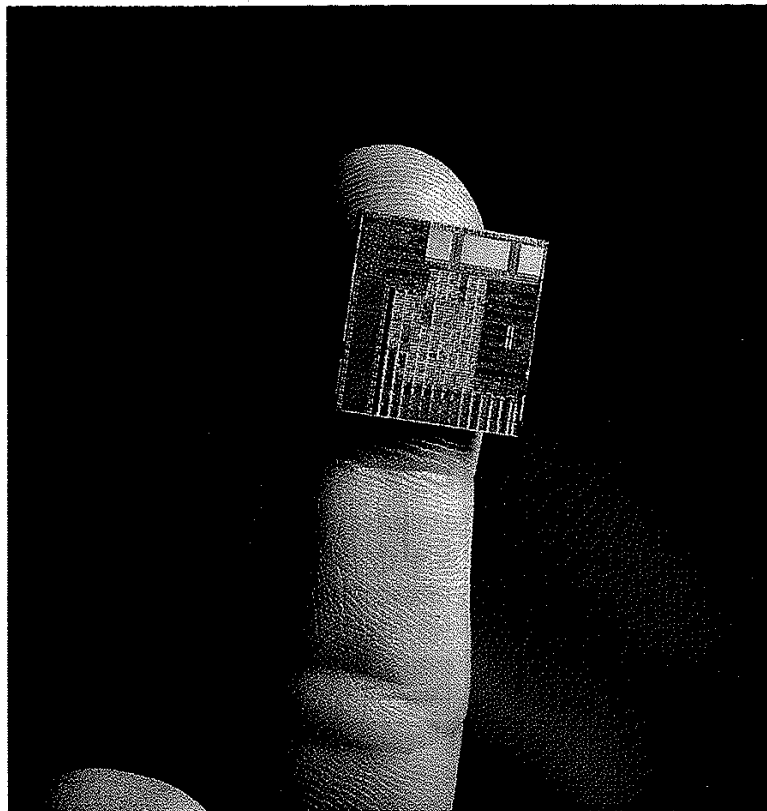



Salas Blancas





Diseño del microcircuito



ILUSTRACIONES: BARRY FOSS



El cristal de silicio

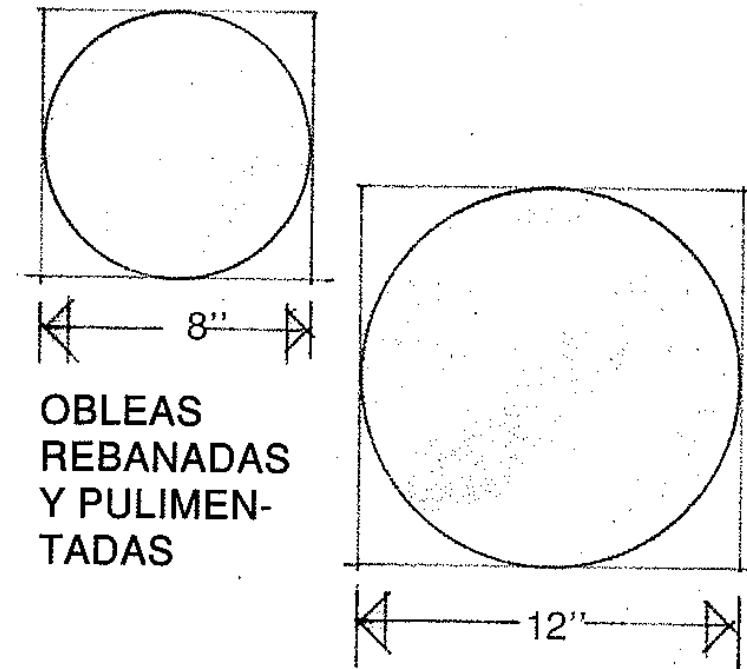



Primeros estratos

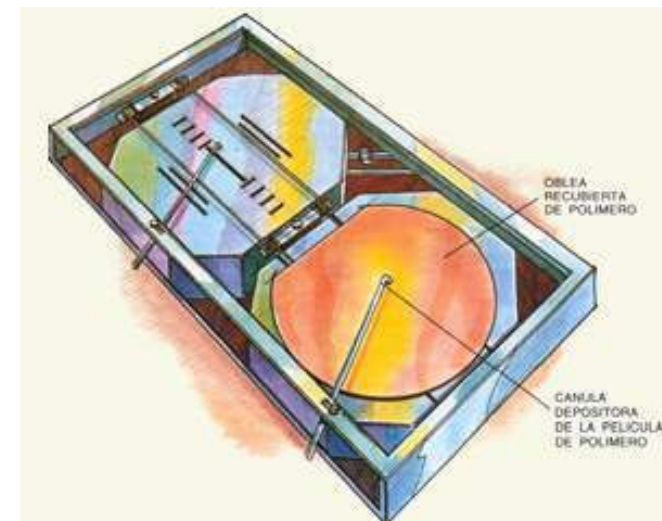
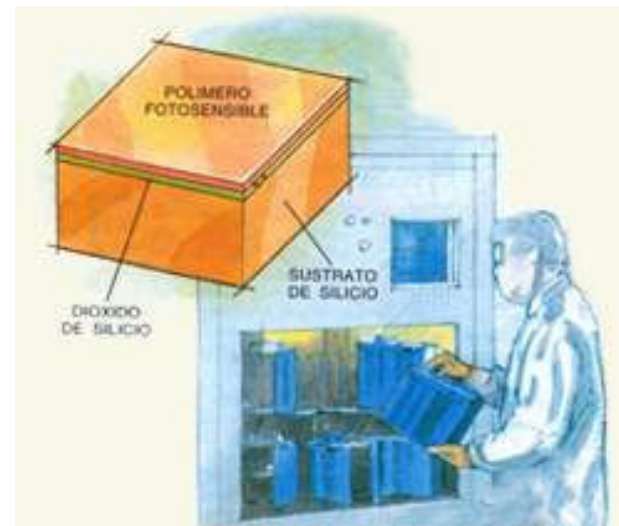
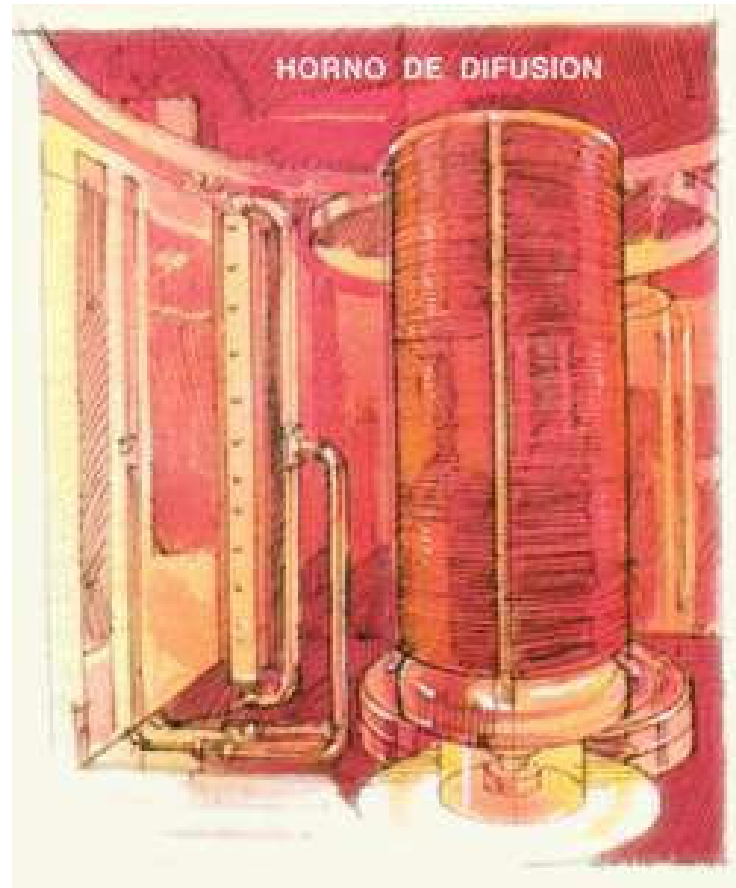

Fabricación de Circuitos Integrados

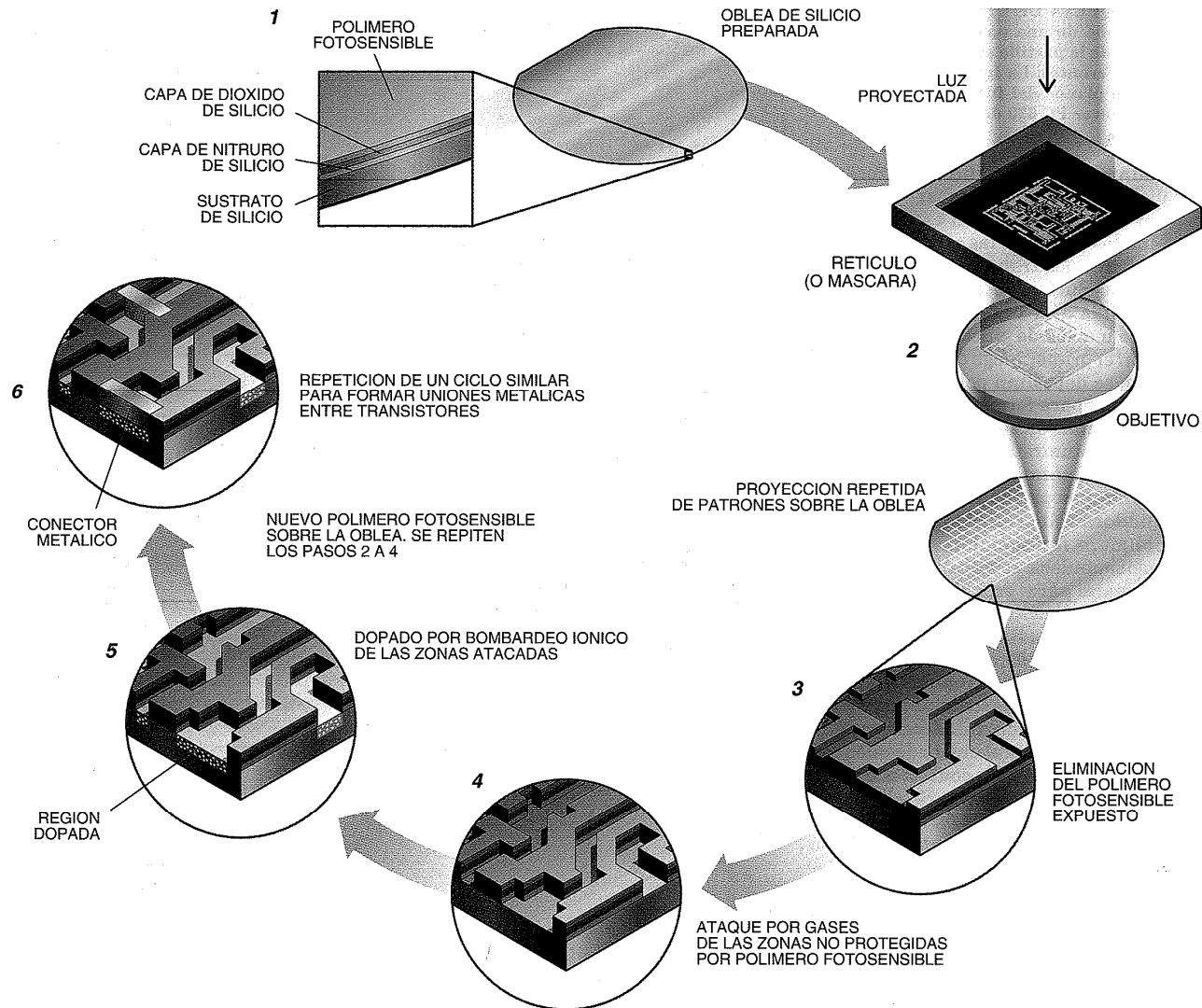

Máscaras

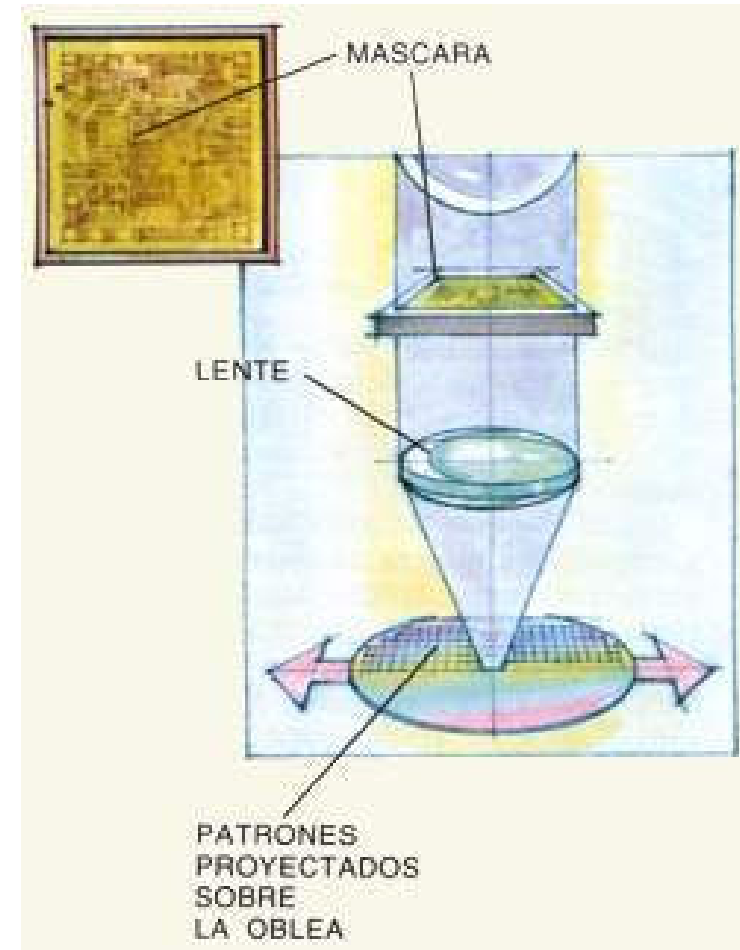
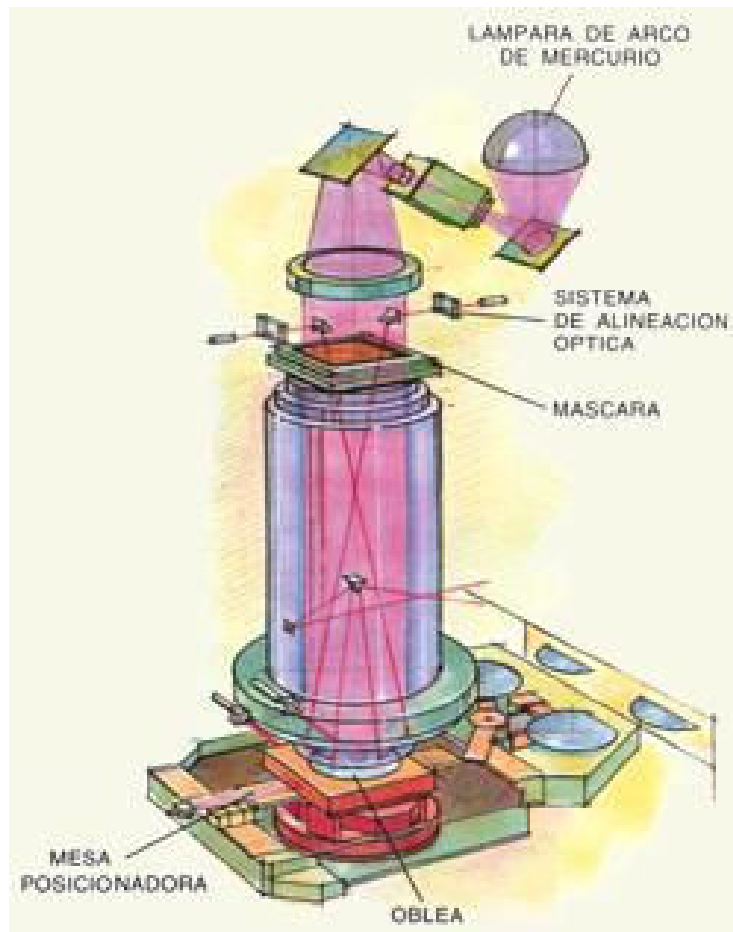



Grabación

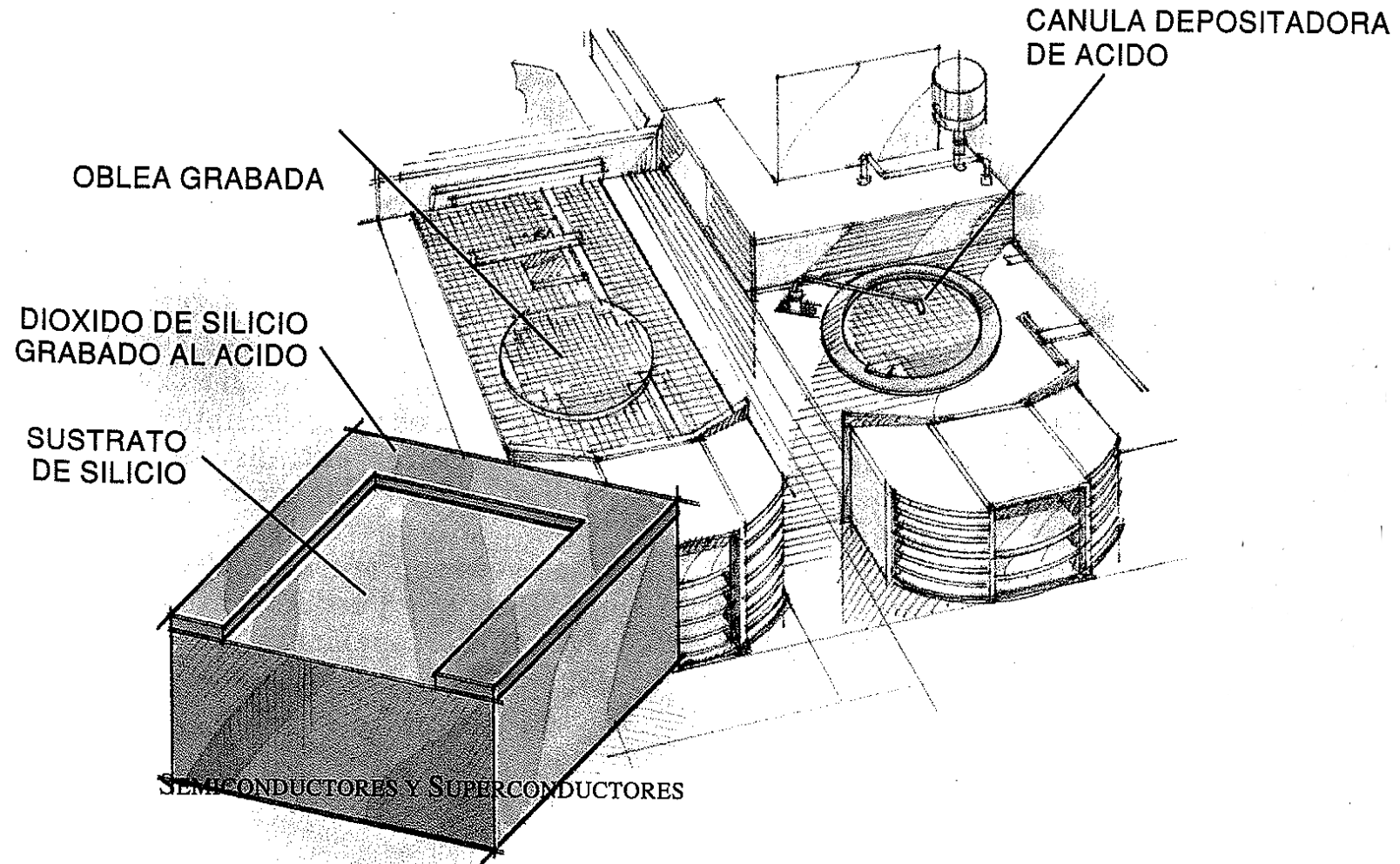



Adición de estratos

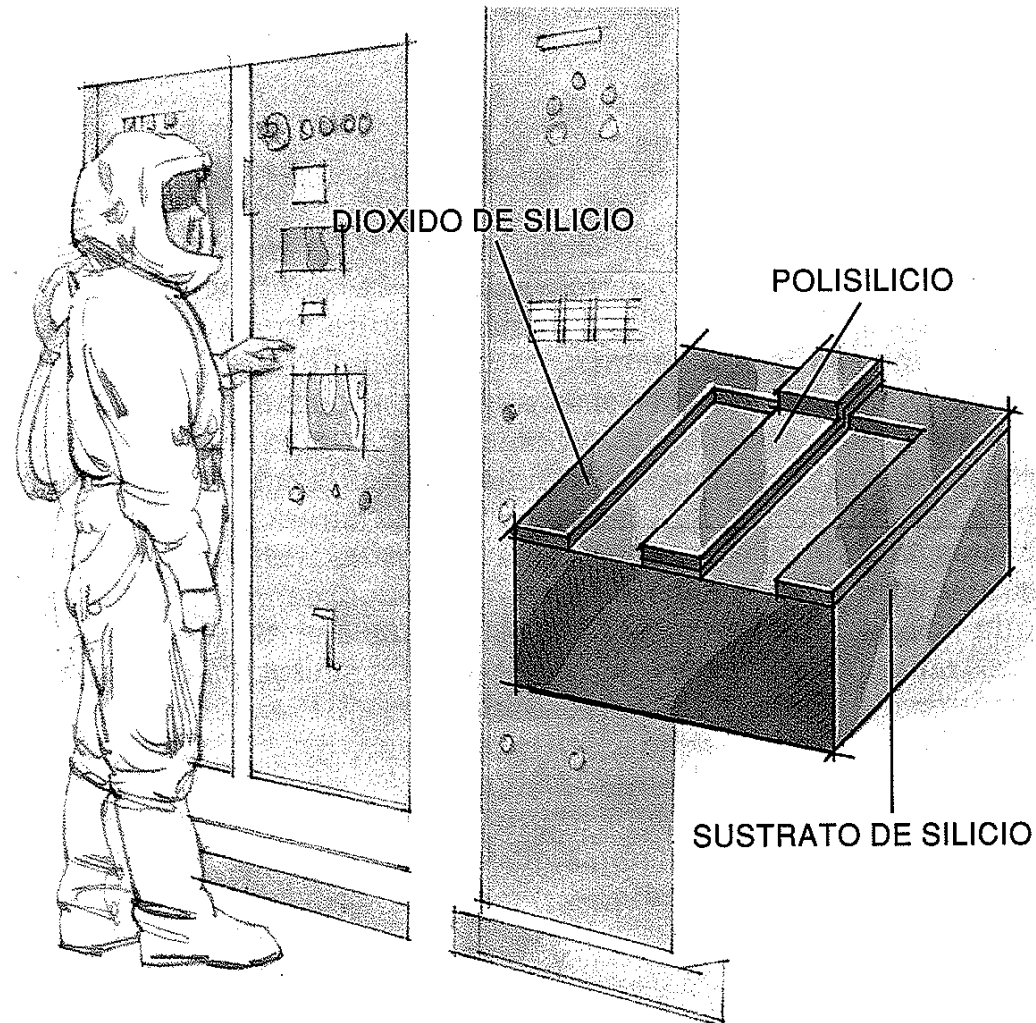



Dopado

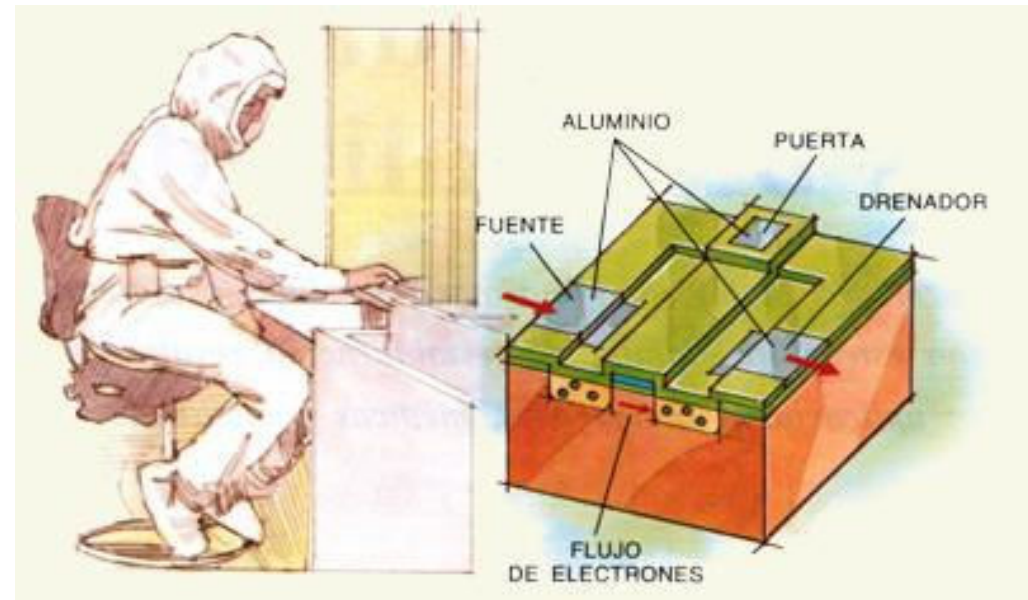
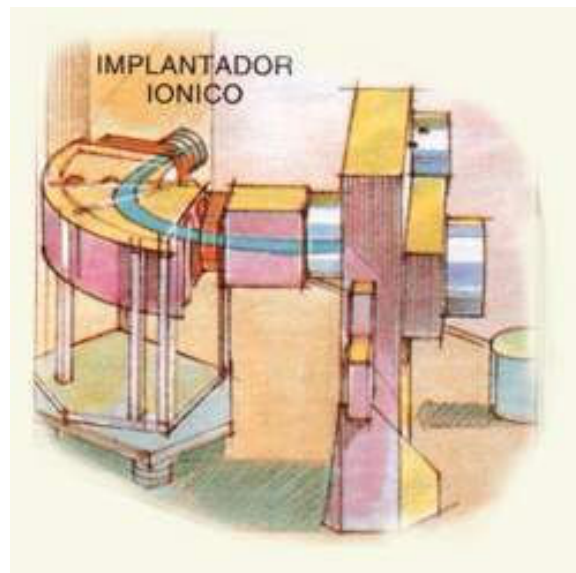
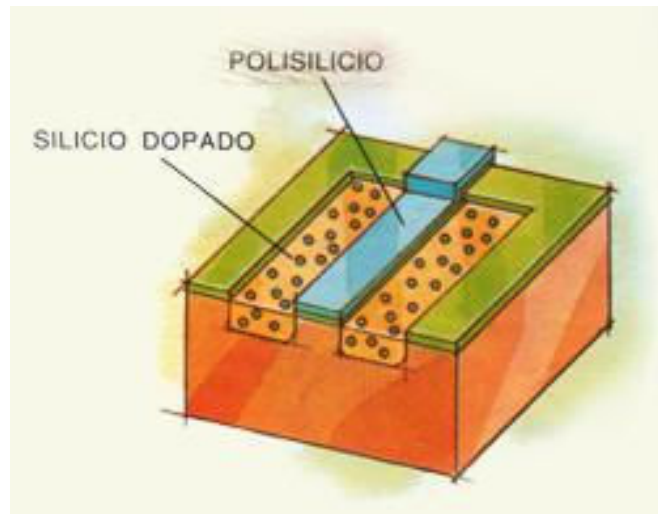



Oblea final

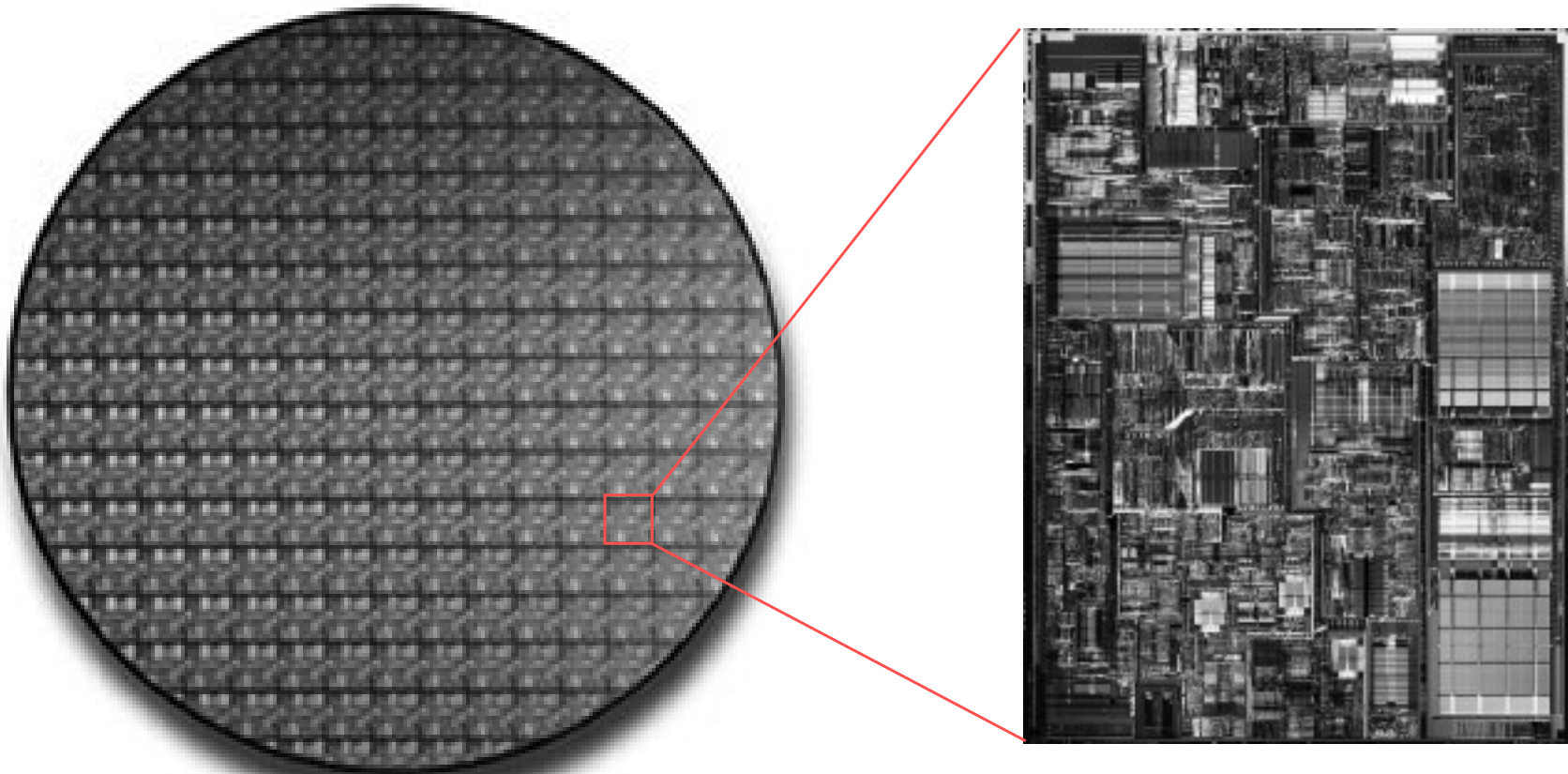



Interconexiones

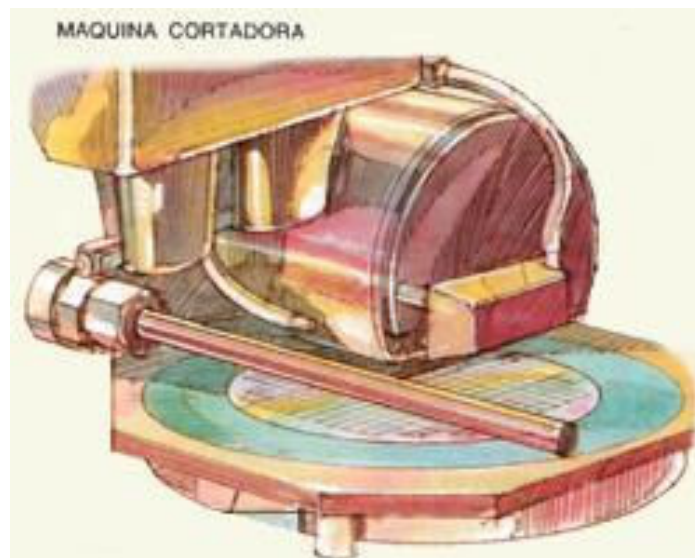
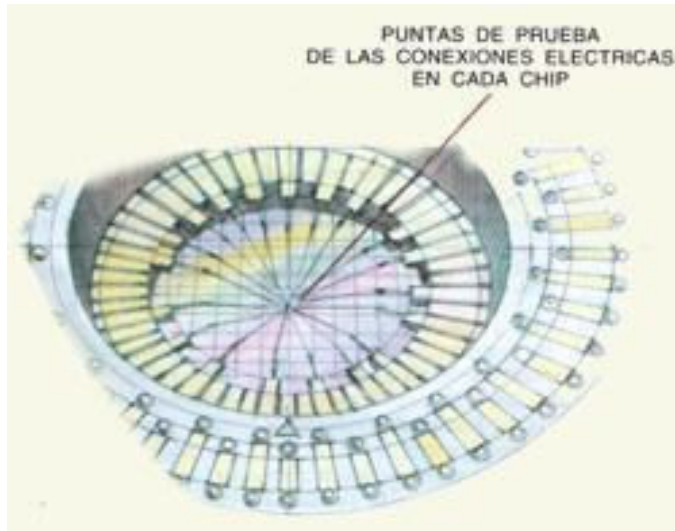

Curvas de costes de fabricación

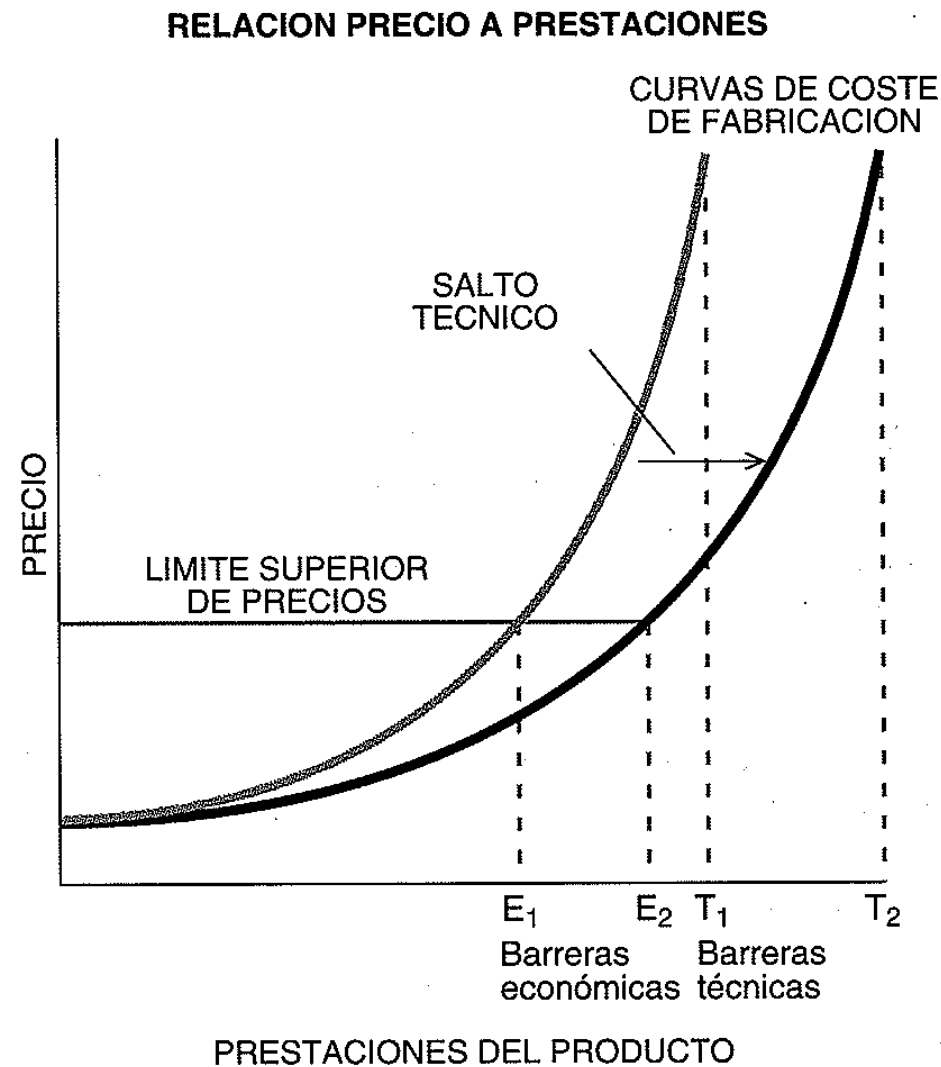



Densidades de transistores en procesadores y memorias

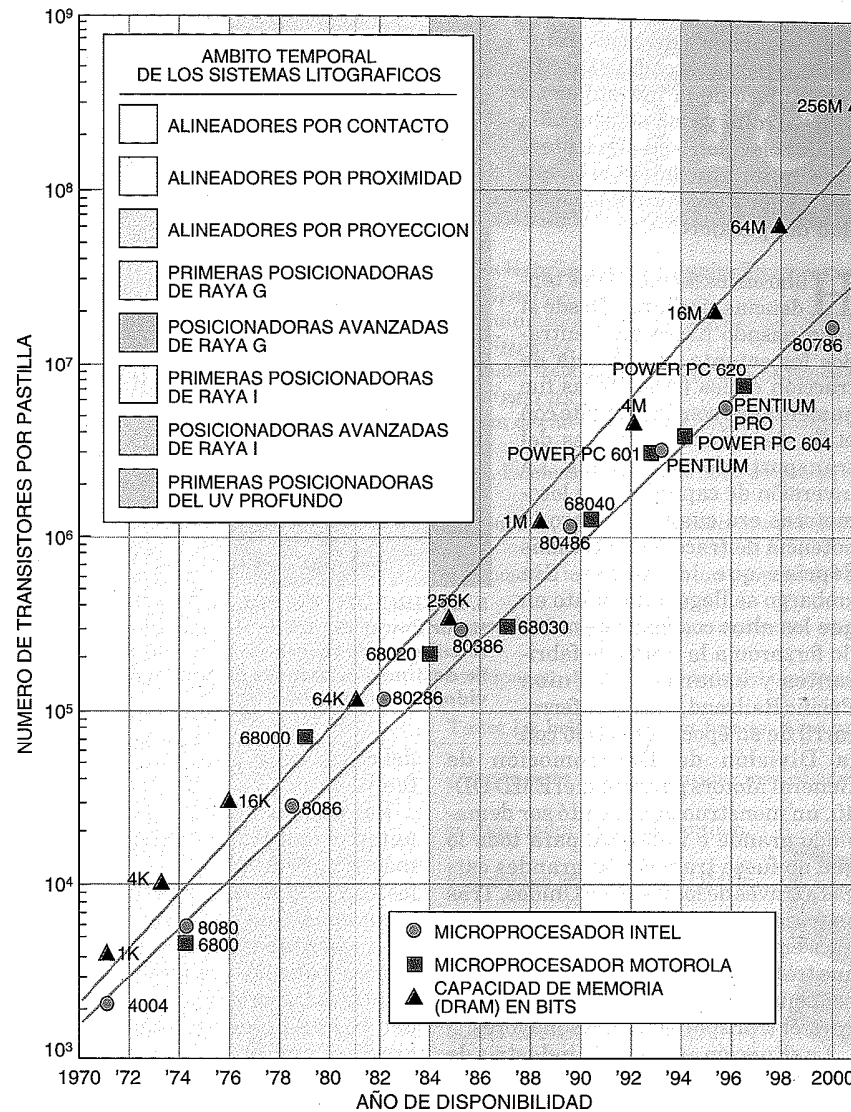



Futuro de la Industria de los Semiconductores

- Precedentes
 - ✓ 40 años de vigencia de la ley de Moore
- Situación actual
 - ✓ Barreras técnicas cada vez más difíciles de superar
 - ✓ Se dispara el coste de las plantas de fabricación
- Futuro probable
 - ✓ Estancamiento del nivel de integración
 - ✓ Cambio de modelo empresarial: mayor diversificación
 - Ejemplos: modelos de mayor fiabilidad, aplicación específica, etc.

Futuro de la Industria de los Semiconductores

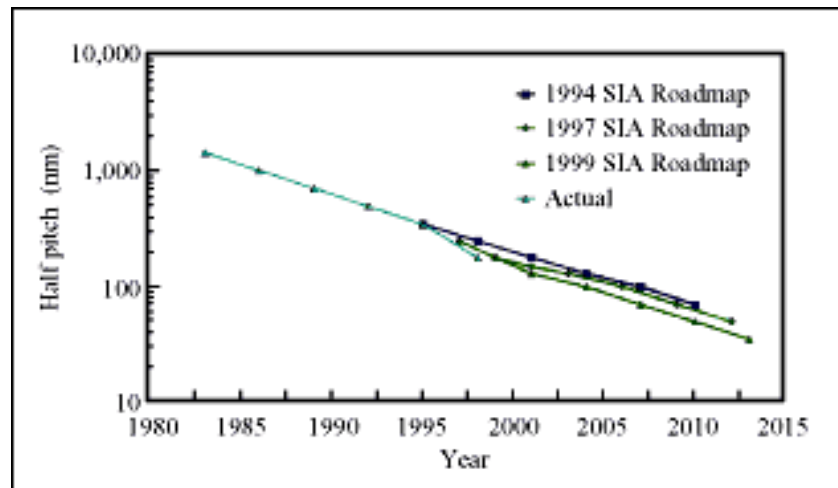

Figure 1

Historical and future trends of lithographic resolution capability. Here, half pitch is the minimum size of lithographic features on a chip. (SIA—Semiconductor Industry Association.)

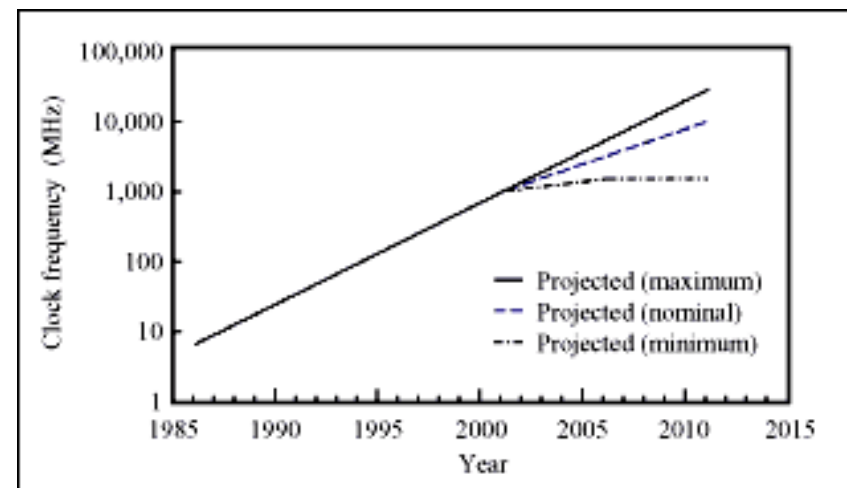

Figure 3

Predicted trend of microprocessor clock frequency for circuits realized in the technology generations represented in Figure 2.



Futuro de la Industria de los Semiconductores

			1999	2002	2005	2008	2011
Technology		nm	180	130	100	70	50
Gate length		nm	140	85–90	65	45	30–32
Density	DRAM	Gb/cm²	0.27	0.71	1.63	4.03	9.94
	SRAM	Million transistors per cm²	35	95	234	577	1423
	High-performance logic		24	65	142	350	863
	ASIC logic		20	54	133	328	811
	High-volume logic		7	18	41	100	247
Local clock frequency	High-performance	GHz	1.25	2.1	3.5	6.0	10.0
	ASIC		0.5	0.7	0.9	1.2	1.5
	High-volume		0.6	0.8	1.1	1.4	1.8

Semiconductor Industry Association (SIA)

Futuro de la Industria de los Semiconductores

The end of the road for silicon?

Max Schulz

Computer chips continue to shrink. But the discovery that a layer of silicon dioxide must be at least four to five atoms thick to function as an insulator suggests that silicon-based microchips will reach the physical limits of miniaturization early next century.

